

⚠ Be sure to read this page before using and after re-assembling the Hit-Air.

Thank you for using the Hit-Air.

For your safety, peace of mind and correct use of your airbag jacket, make sure that items ①-⑤ are confirmed before use as follows:

Caution ⚠

- Unless the Hit-Air is set correctly, it may not work or may cause a malfunction.
- Once a CO₂ cartridge is activated, it cannot be used again. Remove it from the key box without fail.
- Use a Hit-Air CO₂ cartridge only. Do not use any other one.

① A CO₂ cartridge of the right size (capacity) for the model is installed.

The seal attached the cartridge shows its size (capacity).

② Sealed properly (No damage to the seal)

*No seal is attached in case re-assembling is done by yourself.

Unused CO₂ cartridge and the key box are properly sealed at the time of shipment. (*The key ball is set)

- The right size (capacity) cartridge for the model is installed.
- A CO₂ cartridge is tightly screwed into the key box.
- An used/empty cartridge should not be installed.

Caution ⚠ Re-assembling after the activation must be done in accordance with "Re-assembling Key Box" (see page 22 to 25)

The key ball must be set only after the used/empty cartridge is removed from the key box.

③ Is there any deterioration of the wire loop or the coiled wire?

④ A screw hole at the bottom of the key box is visible.

(The setting bolt is removed)

⑤ A coiled wire is set properly.

See "Attaching Coiled wire to Saddle" (page 17 to 19)

⚠ Be sure to tie a knot tightly.

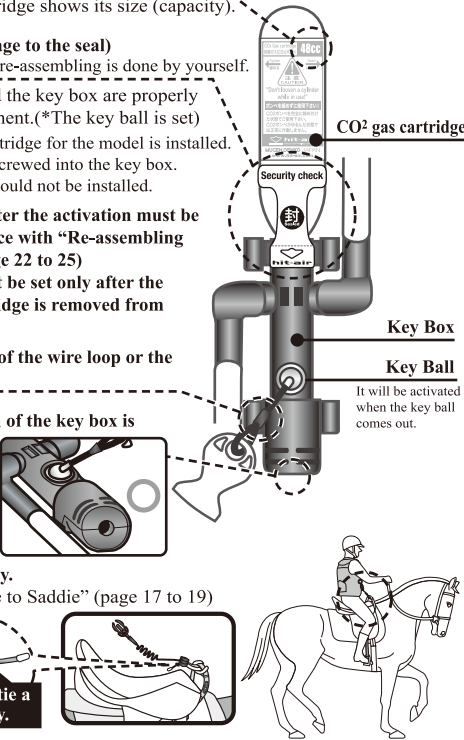

①

②

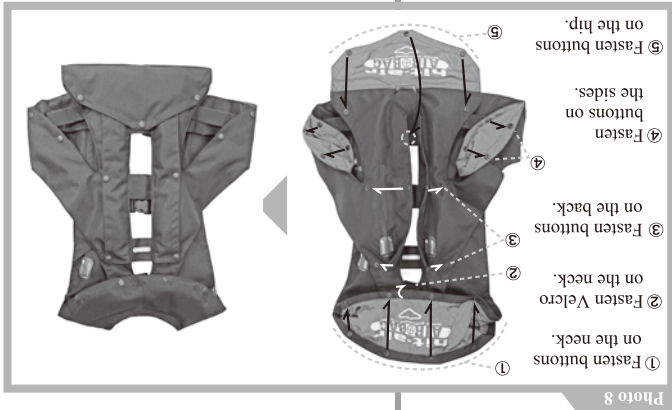

Photo 8

8. Re-pack all air cushions and fasten all buttons (Photo 8)

WARNING ⚠ Remove the setting bolt without fail.



Photo 7

7. Remove the setting bolt. (Photo 7)

Loosen the "setting bolt" by the 5 mm hexagon wrench to remove it.

WARNING ⚠ Remove the "setting bolt" from the "key box" without fail. Otherwise the Hit Air will not be activated.

7-2 Re-assembling Key Box

8 Washing

1. Hit-Air all-in-one airbag/vest should not be washed/laundered.
2. It should not be dipped in the water.
3. It should be dried in the shade if it gets wet.

How to remove stains.

- Wipe with a wet towel.
- Hang it up together with a CO₂ cartridge, spray water on its surface with a shower except on the key box which should not get wet.

9 How to Store

For longer life and safety, avoid the following conditions:

1. High temperature. (Under the direct sunlight, in the closed automobile, near the heater or open flames, etc.)
2. Exposure to rain or extreme moisture, including steam and high humidity
3. Storing items on top of the Hit-Air all-in-one airbag/vest
4. Leaving vest within the reach of children, pets or other animals
5. Folded or rolled up (Hang up on a coat hanger is preferable)

10 Change

If a problem listed below is found on the Hit-Air, consult with an authorized dealer to change or repair/replace.

1. The vest (cloth) or inner fabric becomes frayed or is torn and inner tubing (white polyurethane film) is exposed.
2. A crack or rust is found on the "key box" or on the gas cartridge.
3. The "coiled wire" or the "wire loop" gets scraped and frays.
4. Considerable change of color or deterioration of material.

26

3

10 Change 26

9 How to Store 26

8 Washing 26

7-2 Re-assembling Key Box 22

7-1 How to Re-assemble 21

7 Re-assembling Hit-Air after Activation 21

6 Attention after Activation 20

5-4 How to fix a Coiled Wire 19

5-3 2. How to fix a coiled wire/bungee lanyard to the saddle strap 18

5-2 1. How to fix a coiled wire/bungee lanyard to the Grab Strap/Saddle holder 17

5-1 Attaching Coiled Wire/Bungee Lanyard to Saddle 17

5-2 Connecting Coiled Wire and Hit-Air 16

5-1 One-touch Release 15

5 Using Hit-Air 15

4-6 CO₂ Gas Cartridge 14

4-5 Hit-Air Structure 13

4-4 Key Ball (Y-type) 13

4-3 Key Box (Y-type) 12

4-2 Air Cushion 11

4-1 Function 11

4 Structure 11

3 Name and Shape 9

2 General Information 7

1 Safety Precautions 5

○ Thank you for your purchase.

○ For the proper use of the Hit-air, please read this booklet carefully before use.

○ Please carry this booklet together whenever you use the Hit-Air.